

The **Exotic Collection**
Solid Wood Flooring

Wood Flooring International's Un-finished Solid Wood Flooring Warranty

Section: Forward to Warranty

Pages 2 - 4

- Warranties - How about the Truth !



2 - 4

Section: Wood Flooring International's UF Solid Wood Flooring Warranty

Pages 5 - 10

- Warranty Overview
- Pre-Installation Warranty
- Post-Installation Warranties
- No Finish Warranty
- No Sanding Warranty
- No Structural Warranty
- No Moisture Warranty
- Installer's Responsibilities
- What is not Covered
- "The Fine Print"

5
6
7
7
7
7
7
8
9
10

 	
3/4" x 2-1/4", 3", 4" or 5" Solid Unfinished Flooring	
Drawing: U - F - Solid	Date: February 1, 2005 (1) 856-764-2501 www.wflooring.com

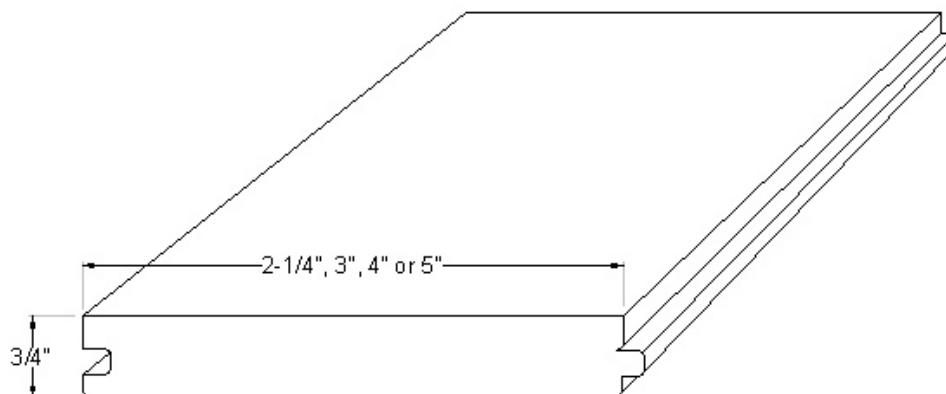

The Exotic Collection *Solid Wood Flooring*

Forward to Warranty - How about the Truth !

The Truth

Wood Flooring International prefers to set the performance expectations for wood flooring and flooring finishes in a realistic manner up front. In doing so, we believe a little truth goes a long way !

If you read most of the other wood flooring manufacturer's warranties you will find in big bold print outlandish claims such as:

Lifetime Finish Warranty & Lifetime Structural Warranty ! Some offer 25 year warranties; some offer 15 year, some merely 10-year warranties. What does it all mean ? Is one manufacturer's product really that much better than another's ? Is one warranty better than another ?

Before we address these issues and delve into what exactly hides in their warranty "fine print", Wood Flooring International would like to look at two separate issues:

The Properties of Wood

All wood flooring is constructed of either solid wood, (just one piece in thickness), or engineered wood, (comprised of several layers of wood). As such, because wood is a living material, it reacts with water in much the same way your kitchen sponge does:

1. It can and will absorb water when exposed to water either in the form of liquid water or also will draw in/give away water from the humidity in the atmosphere and/or also from the subfloor the flooring touches.
2. When it does absorb water, wood swells in size and may cup/crown.
3. When it dries out, wood shrinks in size and may also cup.

The only difference between engineered wood flooring and solid wood flooring is that engineered flooring, because it is bonded in alternating layers with the grain in each layer in an opposite direction, makes the wood somewhat more stable, (partially limiting how much the floor swells/shrinks), than solid wood flooring. However, engineered wood flooring still shrinks/swells as it gains/loses moisture ! And just like a sponge, wood flooring can crown or cup depending on how much and from where the floor gains/loses moisture.

Each species of wood shrinks/swells at a lesser/greater rate unique to each species. This is a simple mathematic formula. (See Wood Flooring International's Species Technical Information – www.wflooring.com/Species Movement-in-Service Chart). For each gain of 1% of moisture content a certain species of wood will gain X% in width. This formula simply represents the physical laws that apply to that individual species of wood and they are immutable.

So, the bottom line is, no manufacturer warrants wood flooring to be impervious to water ! (More on this when we get to the "fine print" section).

The Exotic Collection *Solid Wood Flooring*

Forward to Warranty - How about the Truth !

The Properties of Finishes

All finishes, even with all the recent improvements to durability, will scratch and dent. If you drag something heavy across the floor you scratch the finish and perhaps even get under the finish itself and scratch/gouge the underlying wood, while you also may pull the overlying finish off.

All finishes will dent when pressed hard enough. Depending on the hardness/softness of the wood underneath the finish, the wood itself will dent to an even greater/lesser degree in direct proportion to the wood's hardness. See Wood Flooring International's hardness chart at www.wflooding.com/Species Hardness.

All finishes will wear from abrasion. If you allow sand and grit to lie on the floor, foot traffic will grind the finish down. Excessive foot traffic will also do the same over time. Initially the finish will dull in these areas. Eventually, the finish will wear down to bare wood if not recoated beforehand.

So the bottom line is, once again, no flooring manufacturer warrants their finish to be impervious to wear, much less abuse and all have a long list of what they consider abuse. (Once again, more on this when we get to the "Fine Print" section)

However, the good news is the ongoing finish revolution. In the past 5 years there have been vast technological improvements to flooring finishes with continued advances being made each day. Over the last 5 years, finish wear-ability has increased 5 fold and new formulas are coming on the market just now that increase durability 20 fold. This is the result of adding hard particles to the finish and from the use of new harder resins. While all this improvement brings finished flooring closer to "the holy grail" of total imperviousness, finishes still aren't there yet. Now to the Fine Print !

The Usual Fine Print

Here is what typically is excluded in the fine print from the so-called "Lifetime Warranties" many manufacturers tout today.

On Wood:

- 1) Engineered Wood Flooring – will not delaminate – (only if not soaked in water, either from below/above).
- 2) Engineered Wood Flooring – will not move – (only if not soaked in water from above or below and if installed on a site that is maintained with a relative humidity between 40% and 60%).
- 3) Solid Wood Flooring – after installation, subsequent movement is not covered as it is the installer's responsibility to equalize the flooring.

The **Exotic Collection**
Solid Wood Flooring

Forward to Warranty - How about the Truth !

On Finish:

- 1) Will not peel/blister – (only if not soaked in water or exposed to chemicals/solvents/alkalines/acids).
- 2) Will not wear through to bare wood – (residential use only & only if proper maintenance procedures are followed, meaning keep them clean and free from grit and, in addition, many manufacturers require recoating when showing first signs of wear).

Also, one should be aware that most finish warranties don't consider a change in sheen/gloss levels to be a defect – only peeling or complete wear through is.

The Warranty Killers

Here is what is included in the fine print as warranty “killers” by most manufacturers:

- 1) Soaking in water from above or below.
- 2) Wet mopping & failure to clean up spills.
- 3) Wet subfloor.
- 4) Relative humidity at site below 35% or above 65%.
- 5) Failure to protect the floors from sand/grit, pets, high heels, chair/furniture w/o protectors, lack of mats at entry ways, excessive foot traffic, household chemicals, abrasive cleaners, etc.

Conclusion

So the answer to the question - Is one manufacturer's warranty of “Lifetime” better than another at ten years? - is that the Lifetime Warranty is only slightly better. This is due to the fact that almost all causes for possible product failure (other than manufacturing process failures such as finish adhesion and glue bonds, which almost always appear within one year) are excluded in the fine print anyway !

And, as most reputable flooring manufacturers quickly take advantage of the new improvements to finishes and engineering as they become available from their suppliers, most similar flooring products are roughly equal in performance, regardless of warranty. You just have to be sure that the latest High Wear finishes are being used.

Wood Flooring International's approach to warranties is to be realistic about product performance and equally open about our warranty and its limitations. Our fine print is reserved only for legalese.

Wood Flooring International is also committed to using the latest technological advances in finish and engineering as they become available, always offering the finest flooring on the market.

The **Exotic Collection**
Solid Wood Flooring

Warranty: - Wood Flooring International's Un-finished Solid Wood Flooring

Warranty Overview

What is covered under this Limited Warranty:

Wood Flooring International's Un-finished Solid Wood Flooring, including un-finished Strip, Plank, ThinStrip and FeatureStrip.

Who is covered under this Limited Warranty:

The original buyer/installation site owner when the flooring is used in a residential (as opposed to commercial) setting. (Note: This warranty is non-transferable to subsequent owners.)

Installation Instructions to use:

Wood Flooring International's Un-finished Solid Wood Flooring Installation Instructions

Maintenance Instructions to use:

Wood Flooring International's Maintenance Instructions

Claims Procedures:

In the event of a claim please visit our web site at www.wflooring.com/claim form to download our claim form. Upon receipt of the written claim, Wood Flooring International will act expeditiously to settle the matter but reserves the right to physically inspect the floor and remove samples for lab tests. Wood Flooring International shall report its findings back to you within 60 days of receipt of the written claim.

The **Exotic Collection**
Solid Wood Flooring

Warranty: - Wood Flooring International's Un-finished Solid Wood Flooring

Wood Flooring International Un-finished Solid Wood Flooring Limited Warranty

Wood Flooring International's "Warranties - How about the Truth !"

Please review this section prior to reading this warranty. See pages 2 & 3.

Wood Flooring International warrants our flooring, within Industry Standards #1, to be:

- Free from defects in materials and workmanship when it leaves our possession.
- Of the grade written on our invoice.
- Of the finish quality represented in our samples and in our technical specifications.
- Between 7% - 8.5% moisture content when it leaves our possession.

Note: #1 - Standard industry trade practices allow up to 5% of the flooring shipped to contain milling, handling, finish and/or grade defects. This warranty applies only to that material in excess of 5% that is deemed to be defective. (When ordering flooring, it is standard trade practice to order 7% more flooring than actual coverage needed to allow for cross cutting and fitting waste as well as allowing the installer to set aside any substandard pieces.

Pre-Installation Warranty

- Wood Flooring International will, at its option, either replace or refund the purchase price of any flooring found to be defective, prior to installation, in excess of the 5% of miss-milled/miss-graded/miss-finished product allowed to be included under Standard Industry Trade Practices.
- Wood Flooring International will, at its option, either replace or refund, upon return to Wood Flooring International, the purchase price of any uninstalled flooring found to be at a higher moisture content, than the 7 - 8.5% moisture content Wood Flooring International represents the flooring to be produced to, provided a higher moisture content is not the result of moisture picked up after the flooring leaves Wood Flooring International's possession.

Note: It is the installer's responsibility to check the wood flooring's moisture content first and deem it acceptable for the site as is or to equalize it prior to installation - as Wood Flooring International does not assume responsibility for post-installation movement-in-service issues. The installer must also inspect the flooring as it is installed and set aside or crosscut out defects found prior to installation. Once the flooring has been installed, the installer has deemed the flooring acceptable. Wood Flooring International assumes no further responsibility for defects visible at the time of installation, but installed anyway or moisture that causes subsequent movement, which has been installed anyway.

The **Exotic Collection**
Solid Wood Flooring

Warranty: - Wood Flooring International's Un-finished Solid Wood Flooring

Wood Flooring International Un-finished Solid Wood Flooring Limited Warranty

Post-Installation Warranties

There are no post-installation warranties with solid un-finished flooring as:

- 1) Our pre-installation warranty covers all visible defects, which should not be installed, and are warranted against.
 - 2) Provided you have followed Wood Flooring International's Un-finished Solid Wood Flooring Installation Instructions, you would have taken the following steps, (plus all the additional recommendations from our Installation Instructions). Following these recommendations would eliminate most, if not all, post-installation issues with un-finished solid wood flooring:
 - a) properly equalized the moisture content of the solid wood flooring, prior to installation, to the installation site's equilibrium moisture content point in order to avoid post-installation shrinkage/swelling/cupping issues.
 - b) inspected the subfloor prior to installation to make sure it is dry enough to accept solid wood flooring and not cause subsequent post-installation shrinkage/swelling/cupping issues.
 - c) tested large enough samples, (before installation), with the finish you propose to use in order to make sure the finish is compatible with the wood and also allow the end user the opportunity to approve the look of the proposed finish on test samples before you commence finishing the floor itself.
-

The **Exotic Collection**
Solid Wood Flooring

Warranty: - Wood Flooring International's Un-finished Solid Wood Flooring

Wood Flooring International Un-finished Solid Wood Flooring Limited Warranty

Installer's Responsibilities:

It is the installer's responsibility to follow Wood Flooring International's Un-finished Solid Wood Flooring Installation Instructions, which include complete instructions, in much greater detail than outlined below, on the following topics:

- Inspect the flooring upon arrival to ensure:
 - you received the quantity, species, grade and size flooring you ordered.
 - there was not any handling damage or water damage in transit (in which case you need to lodge a claim with the transport carrier – Call Wood Flooring International, who can assist you with this)
- Prepare an installation plan, based on testing, at the flooring site, of both the subfloor for acceptable moisture content and the site atmosphere for the proper range of relative humidity. The installer must keep a record, which lists the results of all the tests taken. Request a copy of Wood Flooring International's Permanent Installation Record on which to record these results, as Wood Flooring International will request a copy of the job record in reviewing any claims made against this warranty.
- Make sure the flooring received meets the buyer's expectations prior to installation and they approve such issues as:
 - the color/grain range and the color change to be expected in the specie chosen and how the freshly installed floor may vary in look from the aged samples from which their selection was made.
 - establish that the site and sub floor are suitable for the installation method chosen and advise the buyer of, and correct any deficiencies prior to commencing installation.
- Install the flooring properly. This includes:
 - Use of the proper moisture barrier/underlayment, mastic, glue, or nails/staples.
 - Equalize solid wood flooring in advance of installation to match the equilibrium moisture content of the site to avoid subsequent movement.
 - Perform adequate color/grain selecting as you install the floor, so as to not install "odd colored/grained" pieces in conspicuous places, as the owner may reject them later.
 - Protect the flooring and the finish during installation and protect the flooring afterwards from construction and move-in foot traffic to minimize scratching and wear.
- Instruct the end user in proper floor & maintenance care as well as the need to maintain proper relative humidity levels at the site. Please see Wood Flooring International's Maintenance Instructions.

The **Exotic Collection**
Solid Wood Flooring

Warranty: - Wood Flooring International's Un-finished Solid Wood Flooring

Wood Flooring International Un-finished Solid Wood Flooring Limited Warranty

What is not covered under this Limited Warranty includes but is not limited to:

- Claims made on pieces of flooring installed with visible defects as it is the installers responsibility to set aside pieces with visible defects and not use them. Flooring, once installed, is deemed accepted.
- Claims made on pieces of flooring installed with excessive color/grain variation as it was the installers responsibility to inspect the flooring prior to installation and install the floor in a random and harmonious mix.
- Color changes in the wood as it ages or from exposure to sunlight.
- Variation in the color/graining of the installed floor from showroom samples, as the samples most likely will have aged and changed in color, gaining the patina of a partially or fully aged floor.
- Swelling and/or shrinkage or other movement, such as cupping & crowning, in the flooring after installation.
- Excessive swelling, cupping &/or delamination in the flooring caused by an increase of moisture content in the wood from moisture sources below the floor such as a wet sub-floor, or from moisture from above from such sources as spills, excessive wet mopping, pets, etc.
- Insect infestation if it occurs subsequent to the date on which the product passes out of Wood Flooring International's control.
- Damage, excessive movement or defects caused by:
 - improper shipping, handling and/or storage after the product leaves Wood Flooring International's possession.
 - improper preparation or excessive moisture content of the surface on which this product is installed
 - excessive moisture from natural disasters such as flooding, broken pipes, etc., in which case your homeowner insurance company should be contacted.
 - excessive wet mopping or failure to cleanup spills and standing water.
 - improper installation whereby Wood Flooring International's Un-finished Solid Wood Flooring Installation Instructions are not followed.
 - improper application/use including installation over radiant heat which is not covered under Wood Flooring International's Warranty.
 - improper maintenance and failure to follow Wood Flooring International's Maintenance Instructions.
- Finish Damage & Wear caused by:
 - Commercial Use.
 - Abuse /abnormal wear including, pet scratches, indenting from "high heels", dropped or dragged heavy objects, improper maintenance, failure to protect entry & high wear areas with mats, etc. as reviewed in Wood Flooring International's Maintenance Instructions.
 - Any subsequent site refinish compatibility/panelization issues, as this is the site installer/refinisher's responsibility to: 1) adequately test the finish they propose to use for proper adhesion bond and, 2) to get approved by the end user, the look of the finish they propose to use prior to actually re-finishing the floor.

The **Exotic Collection**
Solid Wood Flooring

Warranty: - Wood Flooring International's Un-finished Solid Wood Flooring

Wood Flooring International Un-finished Solid Wood Flooring Limited Warranty

Wood Flooring International Warranty – “the fine print”:

Wood Flooring International neither assumes nor authorizes any other person to assume for it any other obligation in connection with the sale of this product. This writing is the complete and exclusive statement of the warranty, and is in lieu of all other express and/or statutory warranties. Any implied warranties, including, but not limited to the implied warranties, merchantability and fitness for a particular purpose are limited in duration to the duration of this express warranty. Some states do not allow limitations on how an implied warranty lasts, so the above limitation may not apply to you. Wood Flooring International's obligation under this warranty shall be limited to, at its options, providing replacement of shortages, exchange of defective products, or refund of purchase price for flooring with visible defects returned to Wood Flooring international prior to installation. For flooring with delamination and finish defective issues discovered after installation and not visible prior to installation, Wood Flooring International, at its option, will either repair or replace the defective flooring and/or refinish the defective finish. Wood Flooring International assumes no liability for incidental or consequential damages. However, some states do not allow the exclusion or limitation of incidental or consequential damages, so this exclusion may not apply to you. The sole purpose of the remedy provided herein is the replacement/repair of defective products or refund of purchase price. This remedy shall be the buyer's exclusive remedy, and shall not be deemed to have failed of its essential purpose so long as Wood Flooring International is willing to replace/repair such defective goods or refund the purchase price. This warranty does not apply to any product or products designated as seconds, special or nonstandard items. Any product or products so designated are sold “as is”. In order to obtain performance of these warranty obligations, the person seeking performance should contact Wood Flooring International by letter or telephone: Wood Flooring International, Inc., 1810 Underwood Blvd., Delran, NJ 08075 Telephone 856-764-2501 ATTENTION: WARRANTY DEPARTMENT. This limited warranty gives you specific legal rights, and you may also have other rights, which vary, from state to state. Interpretations - this sale shall be governed solely by the terms and conditions herein set forth which shall prevail over any conflicting terms and conditions of buyer, any statement in buyer's purchase order, notwithstanding. All prior writings, representations or negotiations with respect to the subject matter are deemed to be merged herein. The failure of either party to enforce any of the provisions of this agreement shall not be construed as a waiver of such provision or of the right of any party thereafter to enforce each and every provision. The terms of this agreement may not be extended, discharged, amended or modified, in any way, except by a writing signed by an authorized representative of each party. This agreement shall be construed in accordance with the law of the State of New Jersey.
